

EURO 4 'FORWARD' F180.300 18.00T GVW

MANUAL TRANSMISSION

STANDARD VEHICLE PLATED WEIGHTS

GVW 18000KG
GTW 21500KG

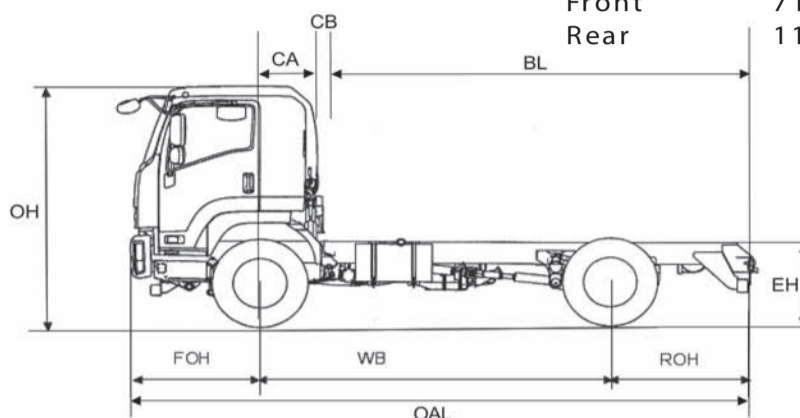
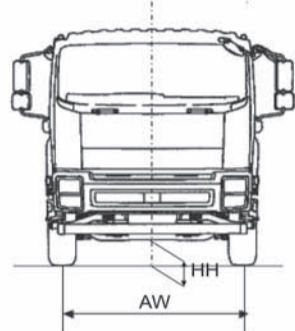

AXLE DESIGN WEIGHTS

Front 7100KG
Rear 11500KG

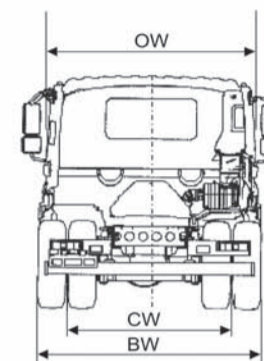

WEIGHTS (KG)

CAB TYPE

WHEELBASE (mm)

	WB	3900	6050	6500
Vehicle Mass Unladen	Front	3195	3440	3470
	Rear	2010	1955	1975
Total		5205	5395	5445
GVW		18000	18000	18000
Max. Permissible Trailer Weight		3500	3500	3500
Body & Payload Allowance		12795	12605	12555

DIMENSIONS (mm)

Overall Length	OAL	6755	10005	10740
Overhang	Front FOH	1440	1440	1440
	Rear ROH	1415	2515	2800
Cab Gap	CB	150	150	150
C/L Front Axle to Rear of Cab	CA	626	626	626
Recommended Body Length	BL	5000	8250	8985
Chassis Frame Width		850	850	850
Recommended Body Width		2550	2550	2550
Recommended Maximum Body Width		2600*	2600*	2600*
Cab Width	OW	2480	2480	2480
Overall Height (Unladen)	OH	2870	2865	2865
Chassis Height (Unladen)	EH	1050	970	970
Minimum Road Clearance	HH	225	225	225
Track	Front AW	2035	2035	2035
	Rear CW	1840	1840	1840
Rear Axle Width	BW	2455	2455	2455

*Max dimension for refrigerated bodies only

F180.300/0209/GW/3K

1. Unladen weights exclude fuel, driver, spare wheel + carrier, tool kit and jack. (Tolerance +/- 3%).
2. Body lengths are given as a guide only. Bodybuilders are responsible for ensuring all legal requirements are met.
3. Maximum body lengths are calculated to remain within the maximum permitted overhang in the UK of 60% of the wheelbase. Cab gaps may vary.
4. Isuzu Truck (UK) Ltd. shall have no liability whatsoever should the information supplied have incorrect data, descriptions or illustrations.

ISUZU
BUILT AROUND U

EURO 4 'FORWARD' F180.300 18.00T GVW

MANUAL TRANSMISSION

Mechanical Specification (standard equipment)

F180.300 18.00T

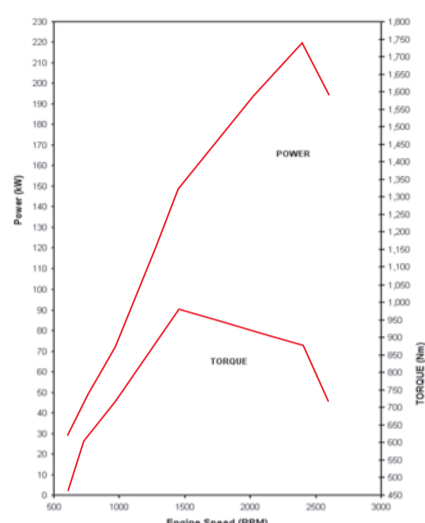

Engine 6HK1TCS

- Isuzu turbo intercooled OHC 6 cylinder diesel (Euro 4)

Bore: 115mm
Stroke: 125mm
Capacity: 7789cc
Max Power: 221 kW (300bhp) at 2400rpm
Max Torque: 981Nm from 1450rpm
Injection Type: Common rail

Euro 4 Compliance: EGR (Exhaust Gas Recirculation) with DPD (Diesel Particulate Defuser)

Fuel Tank

Capacity: 186 litres

Transmission

- 9 speed manual ZF 9S1110
- Ratios: 1st 6.580
2nd 4.700
3rd 3.480
4th 2.620
5th 1.890
6th 1.350
7th 1.000
8th 0.750
9th 9.480 (crawler) reverse 8.970
- Rear Axle Ratio: 4.300:1
- Tyres: 295/80R 22.5 radial, spare wheel and carrier
- Wheels: Steel 22.5 x 8.25, 10-stud

Cab Exterior

- New aerodynamic Isuzu Hexapod design white steel cab
- Tilt to 45 deg.
- Keyless door entry and immobiliser
- Laminated windscreen

- Non-slip entry steps
- 90 deg. opening doors
- Zinc galvanised frame cab structure
- 2 halogen head lamp units
- Front mudguards with spray suppression
- All steel front bumper with fog lights
- Chrome radiator grille

Frame

Parallel ladder type channel section, straight side rails with rivetless upper flange

Cooling

Tube and fin type radiator with fan and viscous clutch

Clutch

Air assisted, 380mm diameter

Cab Interior

- Flame resistant interior trim
- Vinyl floor matting
- Dual long grab handles each side
- SRS airbags driver and passenger
- Header console storage
- Interior fluorescent lighting
- Multi information display
- Rear rest/sleeper section with 650mm width bunk

Seats (all cloth)

- Driver's adjustable air-suspended seat with head restraint and 3-point seat belt with pre-tensioner
- Rigid centre seat with 2-point seatbelt
- Rigid passenger seat with head restraint and 3-point seat belt with pre-tensioner

Vision

- Large door mounted heated mirrors
- Front underview mirror
- Driver and passenger sun visors
- Deep cut side windows to reduce blind spots
- Electric windows with driver control and lock

Heating & Ventilation

- 4 - Speed blower
- Multiple cab vents

Axles

Front: Reverse Elliott I-Beam
Rear: Banjo type, fully floating

Suspension

Front: Multi-leaf steel springs
Rear: Multi-leaf steel springs on 3900, Hendrickson 2 bag air with height control on 6050 and 6500 wheelbases

Steering

- Recirculating ball type with full integral hydraulic power assistance
- Tilt and telescopic steering column

Brakes

Full air with ABS
Front: Disc 434mm x 44mm
Rear: Disc 434mm x 44mm
Park: Rear Wheel
Air dryer

Instruments

- Rev counter
- Tachograph, digital Siemens VDO
- Speedometer with odometer and trip
- Gauges: Fuel level, coolant temperature and air pressure

Switches & Electrical

- Electrical vehicle speed limiter set at 56 mph (90 kph) with automatic cruise control
- Steering column mounted switch for indicators, side lights, headlights, high beam, front and rear fog lamps
- Wiper and washer (2-speed and intermittent)
- Exhaust brake
- Brake warning buzzer
- Steering wheel horn switch
- Hazard lights
- Head lamp levelling

- Interior light
- key operation for quick cold start, start and stop
- Cigarette lighter
- Central locking
- Reverse warning buzzer in cab
- DPD engage
- Fast engine idle
- Heated mirrors switch

Warning Lamps

- Battery charge
- Oil pressure
- check brake system
- Low fuel
- Glow plug operation
- High beam indicators
- Parking brake on
- Exhaust brake operation
- Fuel/water separator
- Check engine
- ABS warning
- Service warning
- DPD engaged/warning
- OBD
- Front and rear fog lights
- Air pressure warning

Tool Kit

- Jack with a small selection of hand tools

Radio

RDS radio with CD player

Storage Space

- Centre seat back compartment
- Door pockets
- Twin overhead lockers
- Centre tray
- Dashboard pockets

Ancillaries

Starter: 24 V x 5 kW
Alternator: 24 V - 90 Amp
Quick Start: 6 glow plugs on start relay
Battery: 2 x 12 V - 115 AH

The following optional items are available:

- Aluminium Wheels • Chrome Wheel Trims • Satellite Navigation • Isuzu Branded Mats • Aerodynamic Roof Spoiler
- Headboards • Reversing Aids • PTO Switch • Chassis Lubrication Systems

For further information please contact your local agent, ring us directly on
01707 28 29 30 or visit our website www.isuzutruck.co.uk

ISUZU TRUCK (UK) LTD,
ISUZU HOUSE,
164 GREAT NORTH ROAD,
HATFIELD,
HERTFORDSHIRE AL9 5JN

ISUZU
BUILT AROUND U