

# EURO 4 'FORWARD' F150.260 15.00T GVW MANUAL TRANSMISSION

F150.260 15.00T

## STANDARD VEHICLE PLATED WEIGHTS

GVW 15000KG  
GTW 18500KG

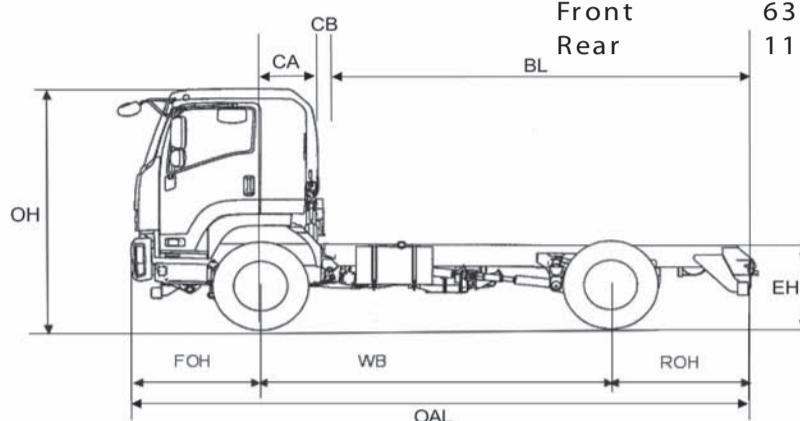
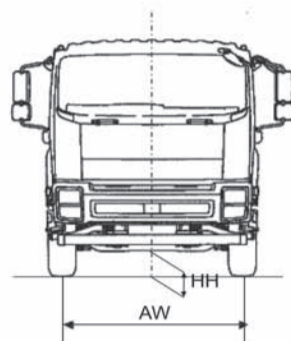

## AXLE DESIGN WEIGHTS

Front 6300KG  
Rear 11500KG

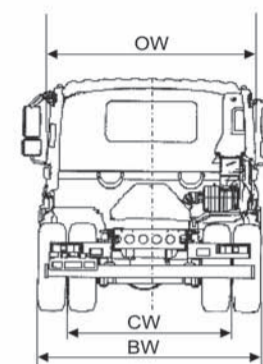

## WEIGHTS (KG)

### CAB TYPE

### WHEELBASE (mm)

|                                 | WB    | 3900  | 4650  | 5550  | 6050  |
|---------------------------------|-------|-------|-------|-------|-------|
| Vehicle Mass Unladen            | Front | 3120  | 3175  | 3375  | 3410  |
|                                 | Rear  | 1940  | 1970  | 1895  | 1920  |
| Total                           |       | 5060  | 5145  | 5270  | 5330  |
| GVW                             |       | 15000 | 15000 | 15000 | 15000 |
| Max. Permissible Trailer Weight |       | 3500  | 3500  | 3500  | 3500  |
| Body & Payload Allowance        |       | 9940  | 9855  | 9730  | 9670  |

## DIMENSIONS (mm)

|                                |           |       |       |       |       |
|--------------------------------|-----------|-------|-------|-------|-------|
| Overall Length                 | OAL       | 6755  | 7955  | 9255  | 10005 |
| Overhang                       | Front FOH | 1440  | 1440  | 1440  | 1440  |
|                                | Rear ROH  | 1415  | 1865  | 2265  | 2515  |
| Cab Gap                        | CB        | 150   | 150   | 150   | 150   |
| C/L Front Axle to Rear of Cab  | CA        | 626   | 626   | 626   | 626   |
| Recommended Body Length        | BL        | 5000  | 6200  | 7475  | 8250  |
| Chassis Frame Width            |           | 850   | 850   | 850   | 850   |
| Recommended Body Width         |           | 2550  | 2550  | 2550  | 2550  |
| Recommended Maximum Body Width |           | 2600* | 2600* | 2600* | 2600* |
| Cab Width                      | OW        | 2480  | 2480  | 2480  | 2480  |
| Overall Height (Unladen)       | OH        | 2825  | 2825  | 2825  | 2825  |
| Chassis Height (Unladen)       | EH        | 1006  | 1006  | 928   | 928   |
| Minimum Road Clearance         | HH        | 186   | 186   | 186   | 186   |
| Track                          | Front AW  | 2035  | 2035  | 2035  | 2035  |
|                                | Rear CW   | 1840  | 1840  | 1840  | 1840  |
| Rear Axle Width                | BW        | 2440  | 2440  | 2440  | 2440  |

\*Max dimension for refrigerated bodies only

F150.260/0209/GW/3K

- Unladen weights exclude fuel, driver, spare wheel + carrier, tool kit and jack. (Tolerance +/- 3%).
- Body lengths are given as a guide only. Bodybuilders are responsible for ensuring all legal requirements are met.
- Maximum body lengths are calculated to remain within the maximum permitted overhang in the UK of 60% of the wheelbase. Cab gaps may vary.
- Isuzu Truck (UK) Ltd. shall have no liability whatsoever should the information supplied have incorrect data, descriptions or illustrations.

**ISUZU**  
BUILT AROUND U

# EURO 4 'FORWARD' FL50.260 15.00T GVW MANUAL TRANSMISSION

FL50.260 15.00T

Mechanical Specification (standard equipment)

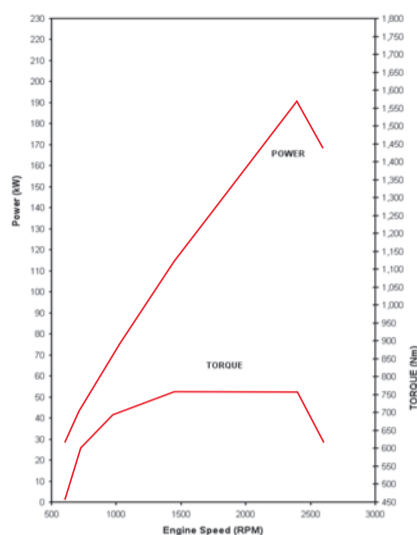

## Engine 6HK1TCC

- Isuzu turbo intercooled OHC 6 cylinder diesel (Euro 4)
- Bore: 115mm
- Stroke: 125mm
- Capacity: 7789cc
- Max Power: 191kW(260bhp) at 2400rpm
- Max Torque: 761Nm from 1450rpm
- Injection Type: Common rail
- Euro 4 Compliance: EGR (Exhaust Gas Recirculation) with DPD (Diesel Particulate Defuser)

## Fuel Tank

Capacity: 186 litres

## Transmission

- 6 speed manual Eaton FS05206B
- Ratios: 1st 6.080  
2nd 3.530  
3rd 2.090  
4th 1.350  
5th 1.000  
6th 0.790  
reverse 5.430
- Rear Axle Ratio: 5.380:1
- Tyres: 275/70R 22.5 radial, spare wheel and carrier
- Wheels: Steel 22.5 x 8.25, 10-stud

## Cab Exterior

- New aerodynamic Isuzu Hexapod design white steel cab
- Tilt to 45 deg.
- Keyless door entry and immobiliser
- Laminated windscreen

- Non-slip entry steps
- 90 deg. opening doors
- Zinc galvanised frame cab structure
- 2 halogen head lamp units
- Front mudguards with spray suppression
- All steel front bumper with fog lights
- Chrome radiator grille

## Frame

Parallel ladder type channel section, straight side rails with rivetless upper flange

## Cooling

Tube and fin type radiator with fan and viscous clutch

## Clutch

Air assisted, 380mm diameter

## Cab Interior

- Flame resistant interior trim
- Vinyl floor matting
- Dual long grab handles each side
- SRS airbags driver and passenger
- Header console storage
- Interior fluorescent lighting
- Multi information display
- Rear rest/sleeper section with 650mm width bunk

## Seats (all cloth)

- Driver's adjustable air-suspended seat with head restraint and 3-point seat belt with pre-tensioner
- Rigid centre seat with 2-point seatbelt
- Rigid passenger seat with head restraint and 3-point seat belt pre-tensioner

## Vision

- Large door mounted heated mirrors
- Front underview mirror
- Driver and passenger sun visors
- Deep cut side windows to reduce blind spots
- Electric windows with driver control and lock

## Heating & Ventilation

- 4 - Speed blower
- Multiple cab vents

## Axles

Front: Reverse Elliott I-Beam  
Rear: Banjo type, fully floating

## Suspension

Front: Multi-leaf steel springs  
Rear: Multi-leaf steel springs on 3900 & 4650, Hendrickson 2 bag air with height control on 5550 and 6050 wheelbases

## Steering

- Recirculating ball type with full integral hydraulic power assistance
- Tilt and telescopic steering column

## Brakes

Full air with ABS  
Front: Disc 434mm x 44mm  
Rear: Disc 434mm x 44mm  
Park: Rear Wheel  
Air dryer

## Instruments

- Rev counter
- Tachograph, digital Siemens VDO
- Speedometer with odometer and trip
- Gauges: Fuel level, coolant temperature and air pressure

## Switches & Electrical

- Electrical vehicle speed limiter set at 56 mph (90 kph) with automatic cruise control
- Steering column mounted switch for indicators, side lights, headlights, high beam, front and rear fog lamps
- Wiper and washer (2-speed and intermittent)
- Exhaust brake
- Brake warning buzzer
- Steering wheel horn switch
- Hazard lights
- Head lamp levelling

- Interior light
- key operation for quick cold start, start and stop
- Cigarette lighter
- Central locking
- Reverse warning buzzer in cab
- DPD engage
- Fast engine idle
- Heated mirrors switch

## Warning Lamps

- Battery charge
- Oil pressure
- check brake system
- Low fuel
- Glow plug operation
- High beam indicators
- Parking brake on
- Exhaust brake operation
- Fuel/water separator
- Check engine
- ABS warning
- Service warning
- DPD engaged/warning
- OBD
- Front and rear fog lights
- Air pressure warning

## Tool Kit

- Jack with a small selection of hand tools

## Radio

RDS radio with CD player

## Storage Space

- Centre seat back compartment
- Door pockets
- Twin overhead lockers
- Dashboard pockets
- Centre tray

## Ancillaries

Starter: 24 V x 5 kW  
Alternator: 24 V - 90 Amp  
Quick Start: 6 glow plugs on start relay  
Battery: 2 x 12 V - 115 AH

The following optional items are available:

- Aluminium Wheels • Chrome Wheel Trims • Satellite Navigation • Isuzu Branded Mats • Aerodynamic Roof Spoiler
- Headboards • Reversing Aids • PTO Switch • Chassis Lubrication Systems

For further information please contact your local agent, ring us directly on  
**01707 28 29 30** or visit our website [www.isuzutruck.co.uk](http://www.isuzutruck.co.uk)

ISUZU TRUCK (UK) LTD,  
ISUZU HOUSE,  
164 GREAT NORTH ROAD,  
HATFIELD,  
HERTFORDSHIRE AL9 5JN

**ISUZU**  
BUILT AROUND U