

ISUZU 'GRAFTER' N35.150(S) 3.5T GVW

4X2 RIGID SINGLE REAR WHEELS. CHASSIS/CAB

EURO 4

UK STANDARD VEHICLE PLATED WEIGHTS

GVW 3500KG
GTW 7000KG

UK AXLE DESIGN WEIGHTS

Front 1900KG
Rear 2000KG

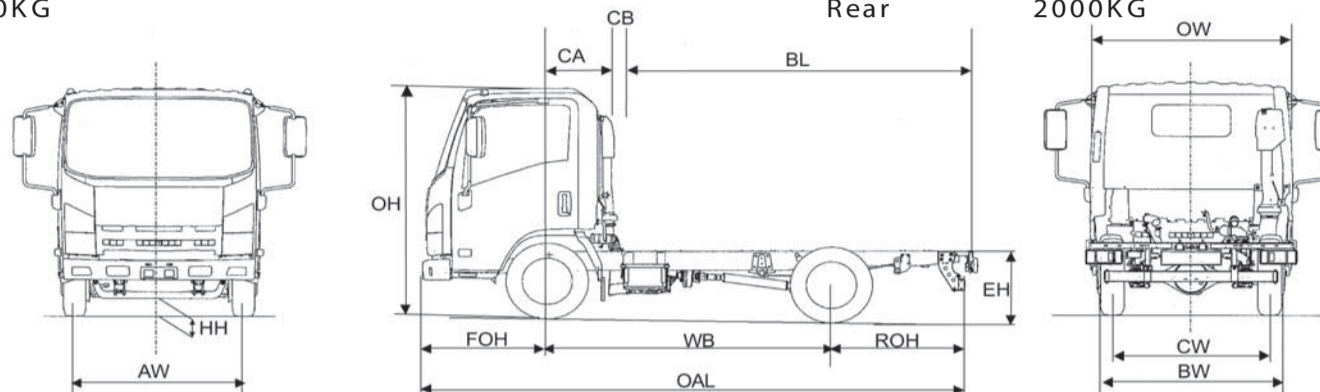

WEIGHTS (KG)

CAB TYPE

day

WHEELBASE

WB

2490

Vehicle Mass Unladen	Front	1390
	Rear	475
Total		1865
GVW		3500
Max. Permissible Trailer Weight		3500*
Body & Payload Allowance		1635

DIMENSIONS (mm)

Overall Length	OAL	4735
Overhang	Front FOH	1100
	Rear ROH	1145
Cab Gap	CB	130
C/L Front Axle to Rear of Cab	CA	463
Recommended Body Length	BL	3200
Chassis Frame Width		700
Recommended Body Width		1828
Recommended Maximum Body Width		1982
Cab Width	OW	1770
Overall Height (Unladen)	OH	2145
Chassis Height (Unladen)	EH	765
Minimum Road Clearance	HH	190
Track	Front AW	1385
	Rear CW	1395
Rear Axle Width	BW	1603

N35.150(S)/0209/GW/3K

* Driver licence and tachograph regulations apply.

- Unladen weights exclude fuel, driver, spare wheel + carrier, tool kit and jack. (Tolerance +/- 3%).
- Body lengths are given as a guide only. Bodybuilders are responsible for ensuring all legal requirements are met.
- Maximum body lengths are calculated to remain within the maximum permitted overhang in the UK of 60% of the wheelbase. Cab gaps may vary.
- Isuzu Truck (UK) Ltd. shall have no liability whatsoever should the information supplied have incorrect data, descriptions or illustrations.

ISUZU
BUILT AROUND U

ISUZU 'GRAFTER' N35.150(S) 3.5T GVW

4X2 RIGID SINGLE REAR WHEELS. CHASSIS/CAB

EURO 4

N35.150 3.5T

Mechanical Specification (standard equipment)

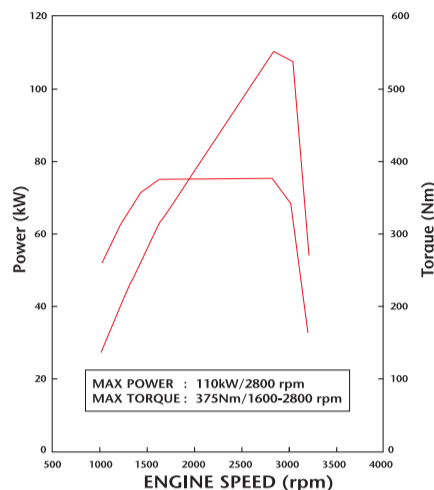

Engine 4JJ1TC

- Isuzu turbo intercooled DOHC 4 cylinder diesel (Euro 4)
- Bore: 95.4mm
- Stroke: 104.9mm
- Capacity: 2999cc
- Max Power: 110kW (150bhp) at 2800rpm
- Max Torque: 375Nm between 1600-2800rpm
- Injection Type: Common rail
- Euro 4 Compliance: EGR (Exhaust Gas Recirculation) with DPD (Diesel Particulate Defuser)

Fuel Tank

Capacity: 68 litres

Transmission

- 5-speed synchromesh MYY5T overdrive
- Ratios: 1st 5.315:1
2nd 3.053:1
3rd 1.655:1
4th 1.000:1
5th 0.721:1
reverse 5.068:1
- Rear Axle Ratio: 4.10:1
- Tyres: 205R16C - radial, spare wheel and carrier
- Wheels: Single rear wheel 5.50J x 16, 6-stud

Cab Exterior

- New aerodynamic Isuzu hexapod design white all steel cab
- Manual tilt to 45 deg.
- Laminated windscreen
- Plastic resin non-slip entry steps
- 90 deg. opening cab doors
- Zinc galvanised cab frame structure
- 2 flush mounted halogen headlamps with side mounted indicators
- Front tyre mudguards with spray suppression
- Composite front bumper with fog lights
- Chrome radiator grille
- Keyless door entry and immobiliser
- Steel rear bumper

Frame

Ladder type channel section straight side rails, riveted upper flanges

Cooling

Radiator: Tube and fin type with fan and viscous clutch

Clutch

300 mm diaphragm type with hydraulic actuation

Cab Interior

- Flame resistant interior trim
- Vinyl floor matting
- Pillar mounted entrance grab handles both sides
- SRS air bags, driver and passenger

Seats (all cloth)

- Drivers fully adjustable with head restraint
- Dual passenger seat with folding back
- Driver and outer passenger retractable diagonal seat belts, with pre-tensioner
- Centre seat lap belt

Vision

- Large foldable door mirrors

- Interior rear view mirror on collapsible mounting
- Driver and passenger sun visors
- Deep cut side windows to reduce blind spots
- Electric windows with driver control

Heating & Ventilation

- 4-speed blower
- Multiple cab vents

Axles

Front: Independent
Rear: Banjo fully floating

Suspension

Front: Independent coil spring and hydraulic shock absorbers
Rear: Parabolic alloy steel leaf springs with hydraulic double acting telescopic shock absorbers

Steering

- Relay box and rack & pinion with full integral hydraulic power assistance
- Tilt and telescopic steering column

Brakes

System: Divided hydraulic servo-assisted with load sensing
Front: 265 mm ventilated discs with asbestos free pads
Rear: 290x75 mm drum with twin actuation self-adjusting asbestos free linings
Park: Mechanical drum brake rear of transmission

Instruments

- Speedometer with odometer & trip
- Rev counter
- Gauges: Fuel level and coolant temperature

Switches & Electrical

- Steering column mounted combination switches for indicators, headlamps (high beam), side and headlamp, exhaust brake and rear fog lamps
- Vacuum warning buzzer
- Wiper and washer (2-speed and intermittent)
- Front fog lamps

- Steering wheel horn switch
- Hazard lights
- Head lamp levelling
- Interior light
- Key operation for quick cold start, start and stop
- Engine quick warm up
- Cigarette lighter
- Central locking
- Reverse warning buzzer in cab
- DPD engage
- Fast engine idle

Warning Lamps

- Battery charge
- Oil pressure
- Check brake system
- Low fuel
- Glow plug operation
- High beam and indicators
- Parking brake on
- Exhaust brake operation
- Fuel/water separator
- Check engine
- DPD operation warning
- Service malfunction warning
- Front and rear fog lamps

Tool Kit

4000 kg jack, with a small selection of hand tools

Radio

RDS Radio / CD Player package

Storage Space

- Compartment box
- Centre console trays
- Door pockets
- Centre facia pockets
- Pop out type cup holder
- Overhead roof shelf
- Drivers seat back pocket

Ancillaries

Starter: Reduction type 24 V – 4.0 kW
Alternator: 24 V – 50 Amp
Quick Start: 4 glow-plugs on start relay
Battery: 2 x 12 V – 75 AH (maintenance free)

The following optional items are available:

- Isuzu Branded Mats • Suspension Seat • Satellite Navigation • Reversing Aids • Digital Tachograph
- Wheelbase Extensions/Reduction • Road Speed Limiter • PTO Switch

For further information please contact your local agent, ring us directly on
01707 28 29 30 or visit our website www.isuzutruck.co.uk

ISUZU TRUCK (UK) LTD,
ISUZU HOUSE,
164 GREAT NORTH ROAD,
HATFIELD,
HERTFORDSHIRE AL9 5JN

ISUZU
BUILT AROUND U